

STAINLESS STEEL ELECTRIC PALLET TRUCK - ULM-EPT-2745-44

APPROX WEIGHT: 1,249 lbs.
DOES NOT INCLUDE WEIGHT OF POWER OR PACKAGING!!!

*** ANY ADDITIONS, DELETIONS, OR OMISSIONS MUST BE CORRECTED ON THIS DRAWING AS THIS DRAWING WILL BE CONSIDERED ALL INCLUSIVE ***

ALL GRAPHICS PROVIDED ARE FOR REFERENCE ONLY. IF CERTAIN DIMENSIONS ARE CRITICAL PLEASE VERIFY THOSE DIMENSIONS WITH YOUR SALESPERSON

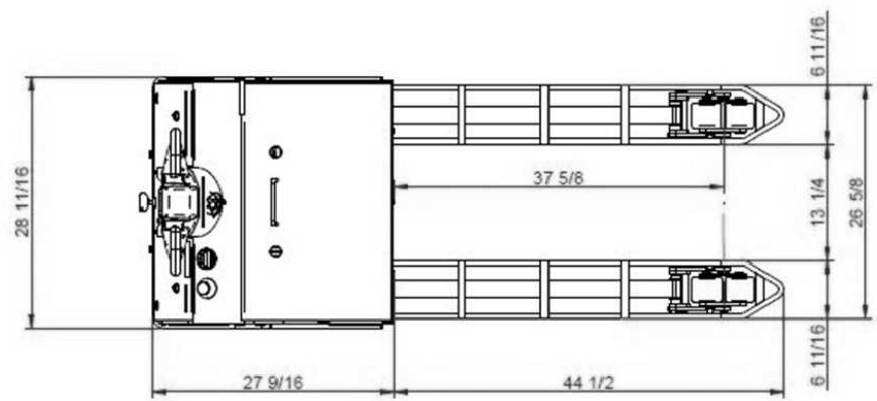
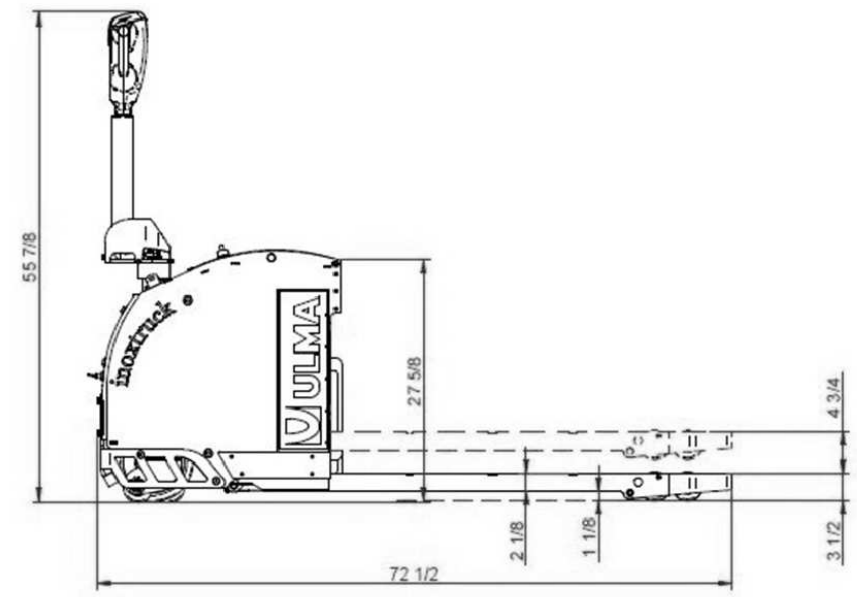
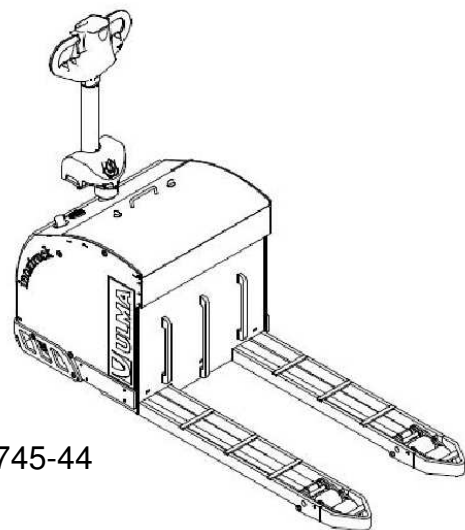

STANDARD FEATURES

- MODEL NUMBER IS ULM-EPT-2745-44
- OVERALL WIDTH: 28 11/16
- OVERALL LENGTH: 72 1/2"
- OVERALL HEIGHT: 55 7/8"
- MAX CAPACITY: 4,400 LBS.
- RAISED HEIGHT: 8 1/4"
- LOWERED HEIGHT: 3 1/2"
- GROUND CLEARANCE UNDER THE FORKS: 1 1/8"
- DRIVE MOTOR: 1.3Kw
- LIFT MOTOR: 2.2Kw
- BATTERY: 24V/240Ah
- TRAVEL SPEED WITH / WITHOUT LOAD: 3.73 / 3.73 mph
- LIFT SPEED WITH / WITHOUT LOAD: 1.22 / 2.16 inch/sec
- DOWN SPEED WITH / WITHOUT LOAD: 0.98 / 0.866 inch/sec
- MAXIMUM GRADEABILITY, WITH / WITHOUT LOAD: 9.1 / 15%

SPECIAL FEATURES

NONE

DIMENSION TOLERANCE ± 1/4"

APPROVAL

I, THE UNDERSIGNED, AGREE THAT THE PRODUCT AS REPRESENTED SATISFIES DESIGN AND DIMENSION REQUIREMENTS. I ALSO ACKNOWLEDGE MY DUTY TO CONFIRM PRODUCT AND INSTALLATION COMPLIANCE WITH ALL APPLICABLE FEDERAL, STATE AND LOCAL REGULATIONS AND STANDARDS.

ANY MODIFIED UNITS ARE NON-RETURNABLE

[] As drawn [] As marked

Signed: _____ Date: _____

Printed Name: _____

LEAD TIME WILL START UPON RECEIPT OF SIGNED APPROVAL DRAWING

FOR INTERNAL USE ONLY PROJECT SIGN OFF	
SALES	
ENG.	
FAB.	
POWER	

DISTRIBUTOR'S NAME: VESTIL MANUFACTURING		P.O.# X
DRAWN BY: CRA		W.O.# X
DATE: 10/18/2017	REFERENCE: X	SALES: X
QUOTED LEAD TIME: X	SCALE: 1:48	FILE NAME: ULM-EPT-2745-44
QUOTE # X		