

SEMI-AUTOMATIC STRAPPING MACHINE, S-2001

Any additions, deletions or omissions must be corrected on this drawing, as this drawing will be considered all inclusive.

STAINLESS STEEL STRAPPING SURFACE

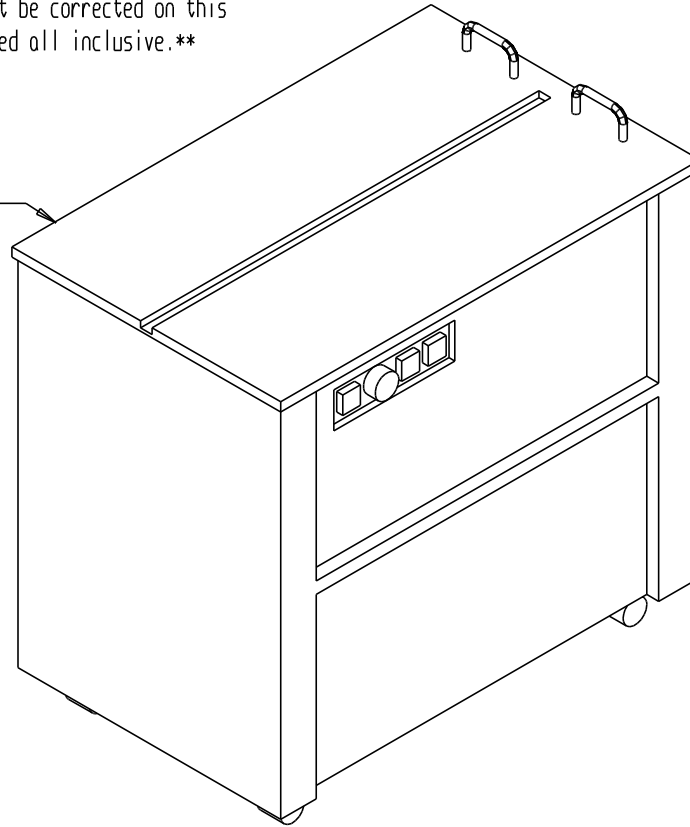

STANDARD FEATURES

MODEL NUMBER: S-2001
 CAPACITY: PACKAGES OR BUNDLES GREATER THAN 3"
 OVERALL WIDTH: 22 1/2"
 OVERALL LENGTH: 35"
 OVERALL HEIGHT: 29"
 STRAPPING WIDTH: 1/2"
 115V POWER SUPPLY

SPECIAL FEATURES

NONE

LEAD TIME WILL START UPON RECEIPT OF SIGNED APPROVAL DRAWING

PLEASE CIRCLE SPECIFICATIONS:

| | | | | |
|----------------------------|--|--------------------------------|------------------------------|------------------------------|
| MOTOR VOLTAGE | <input checked="" type="checkbox"/> 115 | <input type="checkbox"/> 208 | <input type="checkbox"/> 230 | <input type="checkbox"/> 460 |
| DEDICATED CIRCUIT REQUIRED | | | | |
| MOTOR PHASE | <input checked="" type="checkbox"/> SINGLE | <input type="checkbox"/> THREE | | |

All graphics provided are for reference only.
 If certain dimensions are critical please verify those dimensions with your salesperson

| | | | | | |
|---|---|--|-----------------------|------------------|------------|
| FOR INTERNAL USE ONLY PROJECT SIGN OFF | A | I, THE UNDERSIGNED, AGREE THAT THE PRODUCT AS REPRESENTED SATISFIES DESIGN & DIMENSION REQUIREMENTS. I ALSO ACKNOWLEDGE MY DUTY TO CONFIRM PRODUCT & INSTALLATION COMPLIANCE WITH ALL APPLICABLE FEDERAL, STATE AND LOCAL REGULATIONS & STANDARDS. UNITS REQUIRING APPROVAL DRAWINGS OR MODIFIED ARE NON-RETURNABLE () As drawn () As marked Signed: _____ Date: _____ Printed Name: _____ LEAD TIME WILL START UPON RECEIPT OF SIGNED APPROVAL DRAWING | | | |
| | P | | | | |
| | R | | | | |
| | O | | | | |
| | V | | | | |
| L | L | | | | |
| SALES | | DISTRIBUTOR'S NAME: | HOF EQUIPMENT COMPANY | P.O.#: | - |
| ENG | | DRAWN BY: | SR | DATE: | 10-24-05 |
| FAB. | | REFERENCE: | - | SCALE: | 1:10 |
| POWER | | QUOTED LEADTIME: | - | QUOTE #: | - |
| | | PH: | 888-990-1150 | W.O.#: | - |
| | | | | SALES: | - |
| | | | | DRWG./FILE NAME: | 30-007-002 |

**SPECIAL UNITS ARE NON-RETURNABLE
 *AVAILABLE AT ADDITIONAL COSTS