

PORTABLE PALLET INVERTER W/ STRADDLE LEGS - PI-P-SL-3000-3276

*** ANY ADDITIONS, DELETIONS, OR OMISSIONS MUST BE CORRECTED ON THIS DRAWING AS THIS DRAWING WILL BE CONSIDERED ALL INCLUSIVE ***

ALL GRAPHICS PROVIDED ARE FOR REFERENCE ONLY. IF CERTAIN DIMENSIONS ARE CRITICAL PLEASE VERIFY THOSE DIMENSIONS WITH YOUR SALESPERSON

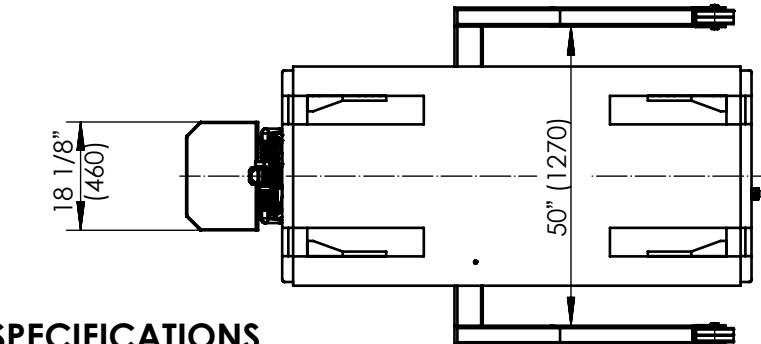
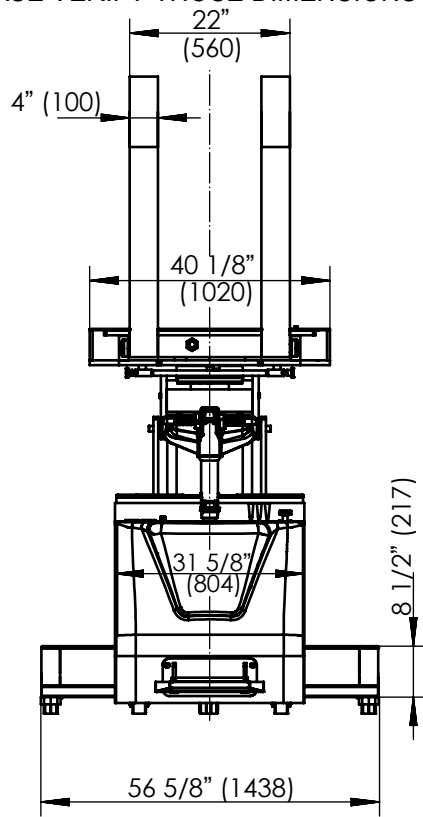
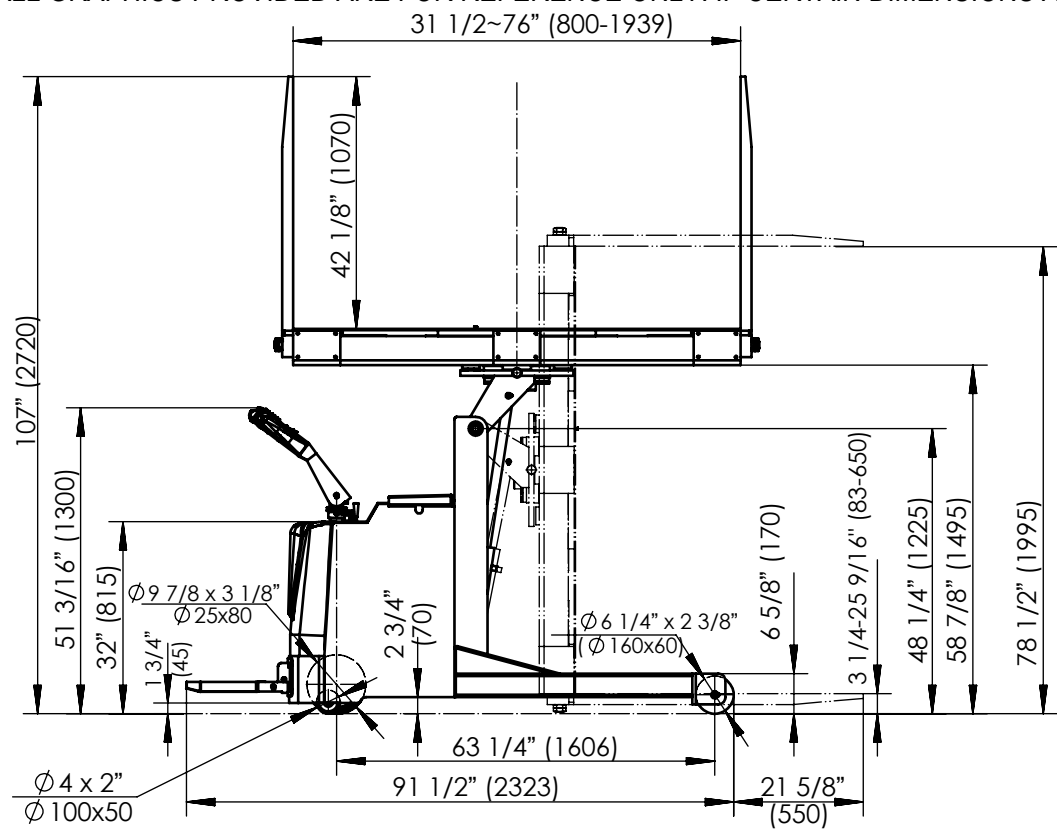

TRAVEL SPEED UNLOADED: 3.7m/h
 TRAVEL SPEED LOADED: 2.5m/h
 DRIVE MOTOR: 24V/1.2KW
 LIFT MOTOR: 24V/2.0KW
 BATTERY: 4 - 6V/200Ah
 BATTERY CHARGER: 24V

DIMENSION TOLERANCE ± 1/2"

SPECIFICATIONS

MODEL NO: PI-P-SL-3000-3276
 CAPACITY: 3,000 LBS
 LOWERED HEIGHT: 3 1/4"
 FORK SIZE: 22" X 42 1/8"
 FORK OPENING: 31 1/2" - 76"
 TURN RADIUS: 84 1/2"
 OVERALL SIZE: 113" X 56 1/2" X 82 1/2"
 TOUGH BAKED IN POWDER COATED
 BLACK & YELLOW FINISH

APPROVAL

I, THE UNDERSIGNED, AGREE THAT THE PRODUCT AS REPRESENTED SATISFIES DESIGN AND DIMENSION REQUIREMENTS. I ALSO ACKNOWLEDGE MY DUTY TO CONFIRM PRODUCT AND INSTALLATION COMPLIANCE WITH ALL APPLICABLE FEDERAL, STATE AND LOCAL REGULATIONS AND STANDARDS.

ANY MODIFIED UNITS ARE NON-RETURNABLE

[] As drawn [] As marked

Signed: _____ Date: _____

Printed Name: _____

LEAD TIME WILL START UPON RECEIPT OF SIGNED APPROVAL DRAWING

FOR INTERNAL USE ONLY PROJECT SIGN OFF	
SALES	
ENG.	
FAB.	
POWER	

DISTRIBUTOR'S NAME:		P.O.#
HOF EQUIPMENT COMPANY		X
PH: 888-990-1150		W.O.#
DRAWN BY: TM		X
DATE: 3/17/2020		SALES: X
REFERENCE: X	SCALE: 1:2	FILE NAME:
QUOTED LEAD TIME: X	QUOTE #	PI-P-SL-3000-3276
	X	