

MODEL NAME - NTAL-10, TANK ACCESS LADDER

APPROX WEIGHT: 58.64 lbs.
DOES NOT INCLUDE WEIGHT OF POWER OR PACKAGING!!!

*** ANY ADDITIONS, DELETIONS, OR OMISSIONS MUST BE CORRECTED ON THIS DRAWING AS THIS DRAWING WILL BE CONSIDERED ALL INCLUSIVE ***

ALL GRAPHICS PROVIDED ARE FOR REFERENCE ONLY. IF CERTAIN DIMENSIONS ARE CRITICAL PLEASE VERIFY THOSE DIMENSIONS WITH YOUR SALESPERSON

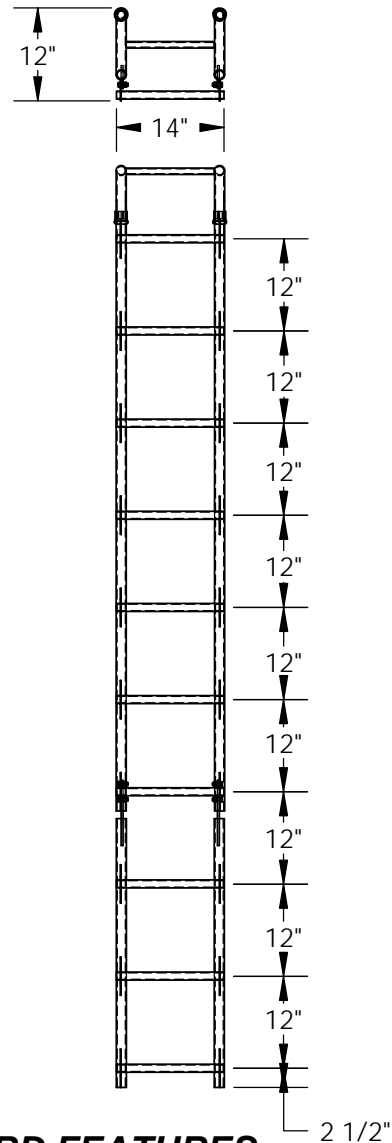

STANDARD FEATURES

- MODEL NUMBER IS NTAL-10
- OVERALL WIDTH IS 14"
- OVERALL LENGTH IS 12"
- OVERALL HEIGHT IS 120"
- USABLE STEP WIDTH IS 13"
- MAX CAPACITY IS 300 IBS.

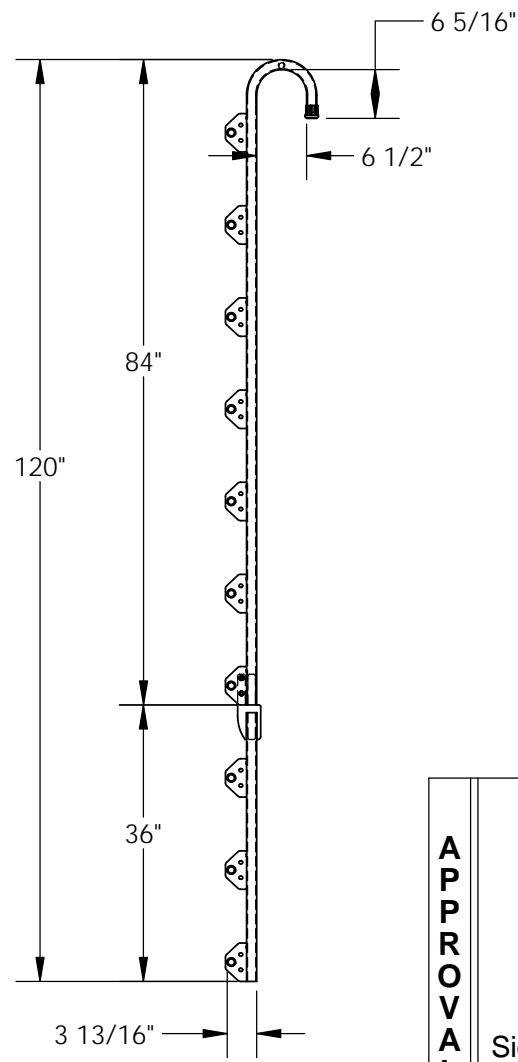

SPECIAL FEATURES

NONE

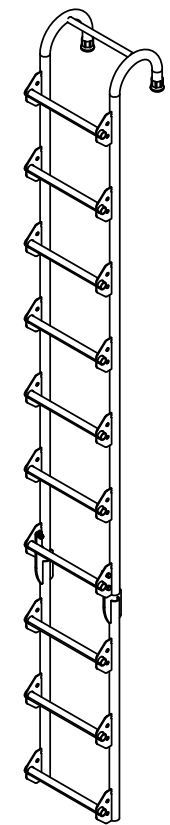

DIMENSION TOLERANCE ± 1/4"

APPROVAL	I, THE UNDERSIGNED, AGREE THAT THE PRODUCT AS REPRESENTED SATISFIES DESIGN AND DIMENSION REQUIREMENTS. I ALSO ACKNOWLEDGE MY DUTY TO CONFIRM PRODUCT AND INSTALLATION COMPLIANCE WITH ALL APPLICABLE FEDERAL, STATE AND LOCAL REGULATIONS AND STANDARDS.	
	ALL SPECIAL UNITS ARE NON-RETURNABLE [] As drawn [] As marked	
Signed: _____		Date: _____
LEAD TIME WILL START UPON RECEIPT OF SIGNED APPROVAL DRAWING		

DISTRIBUTOR'S NAME: HOF EQUIPMENT COMPANY		P.O.# X
PH: 888-990-1150		W.O.# X
DRAWN BY: MIKE S.	DATE: 09/23/2010	SALES:
REFERENCE: X	SCALE: 1:25	FILE NAME:
QUOTED LEAD TIME: X	QUOTE # X	23-007-389