

HYDRA LIFT CART - HYDRA-2

APPROX WEIGHT: 210.54 lbs.
DOES NOT INCLUDE WEIGHT OF POWER OR PACKAGING!!!

*** ANY ADDITIONS, DELETIONS, OR OMISSIONS MUST BE CORRECTED ON THIS DRAWING AS THIS DRAWING WILL BE CONSIDERED ALL INCLUSIVE ***

ALL GRAPHICS PROVIDED ARE FOR REFERENCE ONLY. IF CERTAIN DIMENSIONS ARE CRITICAL PLEASE VERIFY THOSE DIMENSIONS WITH YOUR SALESPERSON

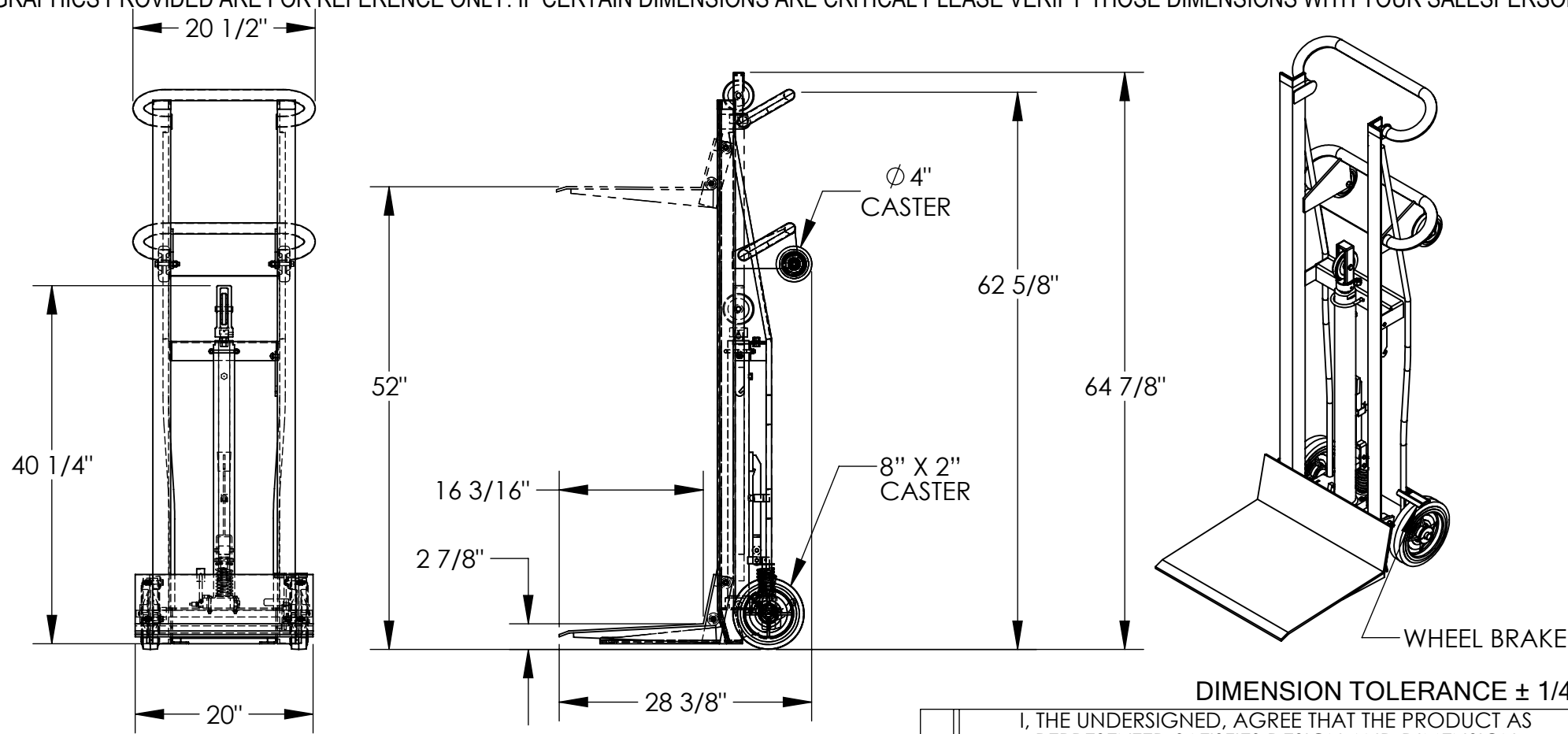

DIMENSION TOLERANCE ± 1/4"

STANDARD FEATURES

- MODEL NUMBER: HYDRA-2
- CAPACITY: 750 LBS
- OVERALL WIDTH: 20 1/2"
- OVERALL LENGTH: 28 3/8"
- OVERALL HEIGHT: 64 7/8" (FULLY RAISED)
- PLATFORM SIZE: 20" WIDE x 16 3/16" LONG
- SERVICE RANGE: 2 7/8" TO 52"
- 8" x 2" WHEELS IN BACK
- SINGLE WHEEL BRAKE
- FOOT PUMP OPERATION
- TOUGH BAKED IN POWDER COATED BLUE FINISH

SPECIAL FEATURES

NONE

APPROVAL

I, THE UNDERSIGNED, AGREE THAT THE PRODUCT AS REPRESENTED SATISFIES DESIGN AND DIMENSION REQUIREMENTS. I ALSO ACKNOWLEDGE MY DUTY TO CONFIRM PRODUCT AND INSTALLATION COMPLIANCE WITH ALL APPLICABLE FEDERAL, STATE AND LOCAL REGULATIONS AND STANDARDS.

ANY MODIFIED UNITS ARE NON-RETURNABLE

[] As drawn [] As marked

Signed: _____ Date: _____

Printed Name: _____

LEAD TIME WILL START UPON RECEIPT OF SIGNED APPROVAL DRAWING

FOR INTERNAL USE ONLY PROJECT SIGN OFF	
SALES	
ENG.	
FAB.	
POWER	

DISTRIBUTOR'S NAME:		HOF EQUIPMENT COMPANY		P.O.#	X
		PH: 888-990-1150		W.O.#	X
DRAWN BY:	DLS	DATE:	9/10/2015	SALES:	X
REFERENCE:	X	SCALE:	1:16	FILE NAME:	
QUOTED LEAD TIME:	X	QUOTE #	X		33-007-105