

Hydraulic Box Dumper Worksheet

Email this survey to info@hofequipment.com or fax to 773-530-1872 (no cover sheet needed).
 Questions? Call us at 888-990-1150.

Company _____ Contact _____ Phone _____

Date _____ Quote# _____ Model# _____

Dumper Specifications

Standard Drum Sizes: 52"W x 48"L _____ 40"W x 36" L _____ Other _____

Dumper Capacity: 2000# _____ Dumper Discharge Height: 36" _____ 48" _____ 60" _____ 72" _____ 84" _____ 96" _____

Dumper Capacity: 4000# _____ Dumper Discharge Height: 36" _____ 48" _____ 60" _____ 72" _____

Dumper Capacity: 6000# _____ Dumper Discharge Height: 36" _____ 48" _____ 60" _____

Overhead Clearance _____ Other Obstructions _____

Dumper Finish: Powder Coat (std) _____ Std Industrial Enamel _____ Stainless Steel _____ Other _____

Standard Colors: EVI Safety Blue _____ Light Blue _____ Dark Blue _____ Profile Gray _____ Safety Yellow _____ Tan _____ Green _____

Dumper Drum Design:

Discharge Options: Product Guides? (to narrow discharge stream) to _____ " Wide

Discharge Chute: _____ " distance from dumper frame

Hold Down Options: Fixed/Custom? Please describe _____

Power/Controls

Voltage: 460 _____ 230 _____ 208 _____ 120 _____ 575 _____ 380 _____ Phase: Single _____ Three _____ Hertz: 50 _____ 60 _____

Controls: Hand Pendant (std) _____ Mounted Panel with pushbuttons _____ Foot Pedal _____ Washdown controls _____

Auto Run Panel with Gated Enclosure _____ Full up limit switch _____

Options

Dumper Options: Stand Mounted _____ Gated Enclosure _____ Power Up/Down _____

Other Specifications _____

Material to be dumped

Please describe material to be dumped: _____

Method of loading dumper: Fork Truck _____ Pallet Jack _____ Rolled on _____ Other _____

Receiving Receptacle: Conveyor _____ Baler _____ Shredder _____ Container _____ Hopper _____ Table _____ Tray _____

Receptacle Opening: Length _____ Width _____ Height from floor _____

Please dimension all containers to be used with dumper:

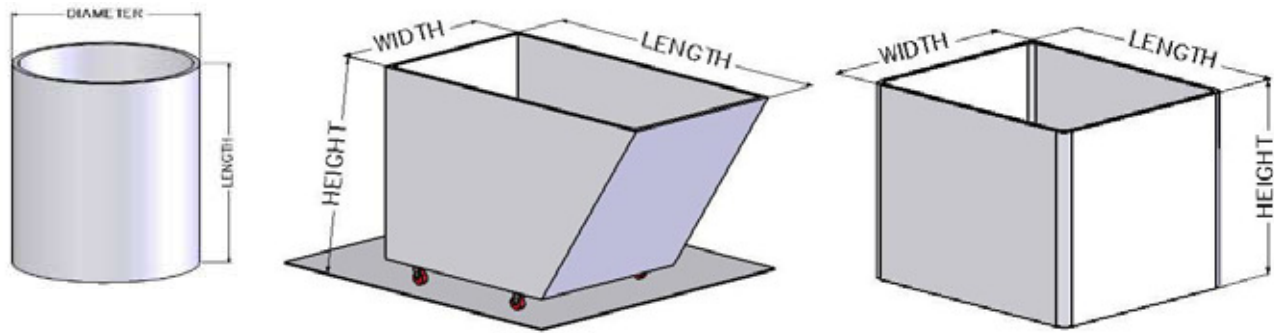

Please indicate the **width** as the side of the container that enters the dumper **first**

MODEL #EV2-60-5250-460

Specifications

CAPACITY (lbs.):	2000
DUMP HEIGHT:	60
OVERALL HEIGHT:	150 7/8
CHUTE WIDTH:	52
CHUTE LENGTH:	50
CHUTE REACH:	10 5/8
HOLD DOWN RANGE:	18-51
ROTATION DEGREE:	135
HORSE POWER:	2
VOLTAGE:	460/3 PHASE
CONTROLS/VOLT:	PUSH BUTTON CONTROLS/120 VAC
LIFT TIME:	33 SECONDS

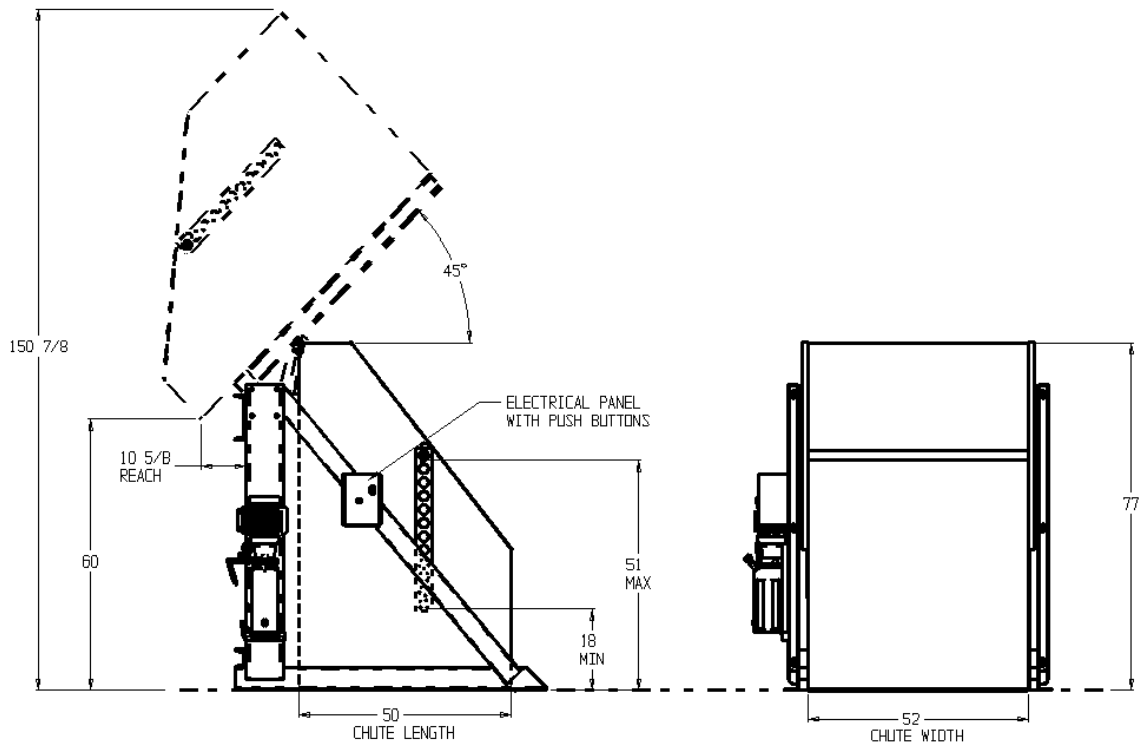

MODEL #EV2-60-5250-460 WITH ENCLOSURE

