

**STANDARD FEATURES:**

- 1 - FOLDABLE DESIGN
- 2 - HEAVY DUTY STEEL CONSTRUCTION.
- 3 - FIXED LEGS.
- 4 - PNEUMATIC AND HYDRAULIC DUAL FUNCTION ENGINE HOIST.
- 5 - ADJUSTABLE BOOM ALLOWS FOR MULTIPLE LIFTING CAPACITY.
- 6 - 8-TON CAPACITY HYDRAULIC LONG RAM PROVIDES FASTER RISING ACTION, AND A LARGE DIA. RAM TO WITHSTAND ANGLE LOADS.

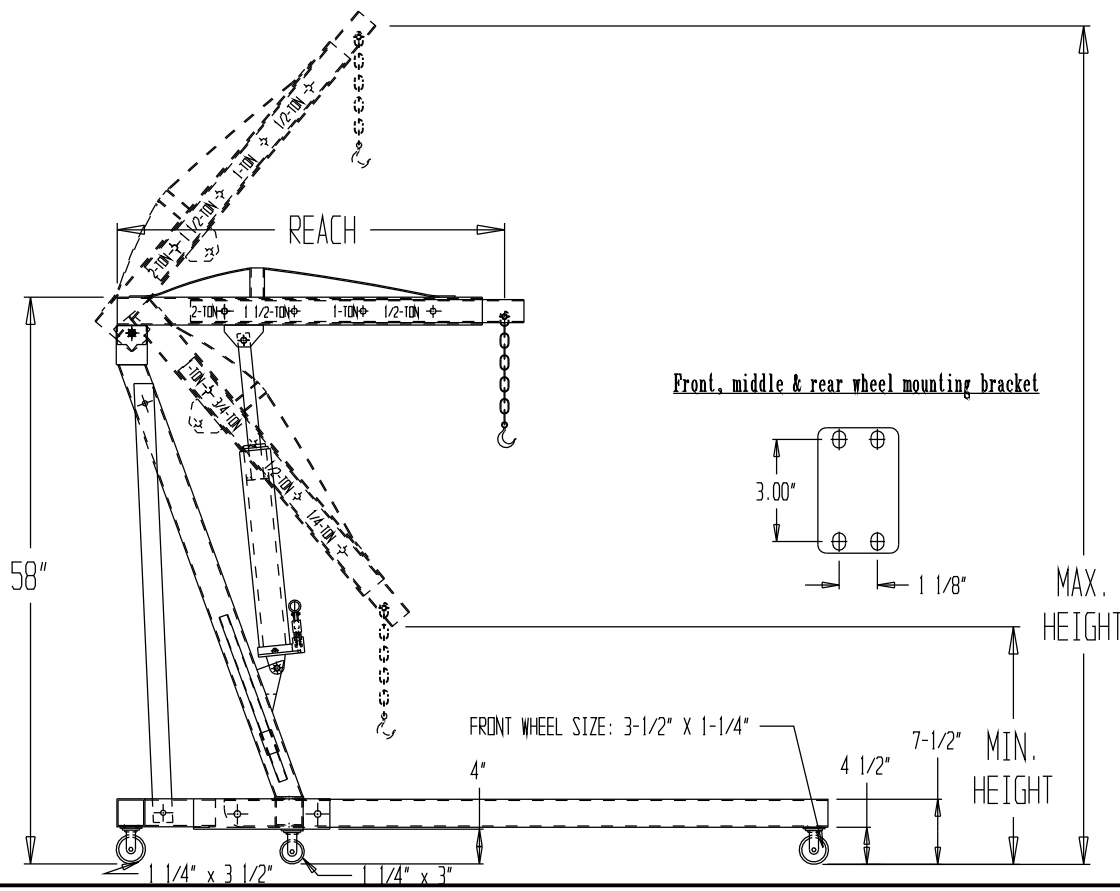

CAPACITY	2 TON	1 1/2 TON	1 TON	1/2 TON
REACH	39"	46"	53"	61"
MAX. HEIGHT	86"	91"	97"	102"
MIN. HEIGHT	21"	15"	9"	3"

OVERALL SIZE (WXLXH): 43" X 72" X 58"

COLLAPSED SIZE (WXLXH): 32" X 22" X 66"

WEIGHT: 200 LBS.

<b>HOF EQUIPMENT COMPANY</b>		
PH: 888-990-1150		
SCALE: 1:14	APPROVED BY:	DRAWN BY: T. MAHMOOD
DATE: 05-12-12		SIZE: B
EHN-40-C-AH (FOLDABLE AIR/HYDRAULIC SHOP CRANE ENGINE HOIST)		
MATERIAL:	DRAWING NUMBER: TM-050507-001	REV: