

# ELECTRIC HYDRAULIC DOCKLEVELER - EH-68-20

APPROX WEIGHT: 1907 lbs.  
 DOES NOT INCLUDE WEIGHT OF POWER OR PACKAGING!!!

\*\*\* ANY ADDITIONS, DELETIONS, OR OMISSIONS MUST BE CORRECTED ON THIS DRAWING AS THIS DRAWING WILL BE CONSIDERED ALL INCLUSIVE \*\*\*

ALL GRAPHICS PROVIDED ARE FOR REFERENCE ONLY. IF CERTAIN DIMENSIONS ARE CRITICAL PLEASE VERIFY THOSE DIMENSIONS WITH YOUR SALESPERSON

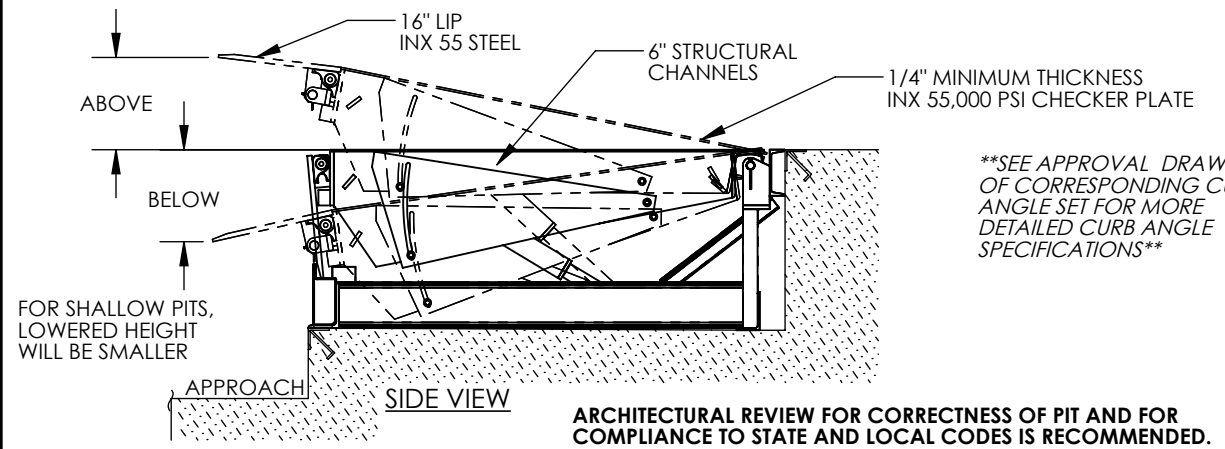

\*\*SEE APPROVAL DRAWING OF CORRESPONDING CURB ANGLE SET FOR MORE DETAILED CURB ANGLE SPECIFICATIONS\*\*

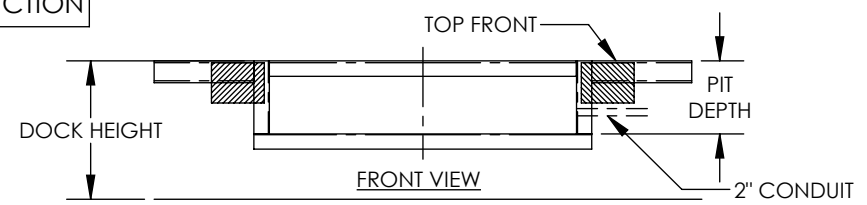
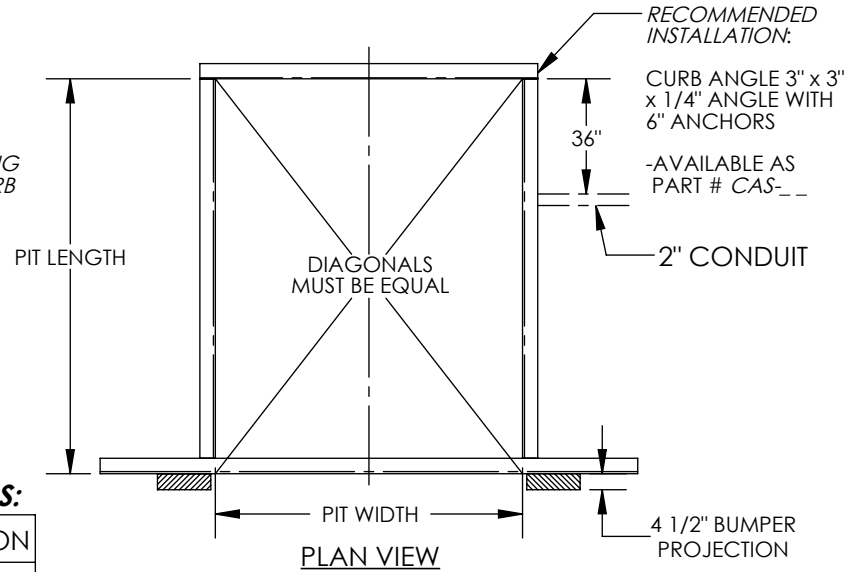

SEE DRAWING NUMBERS EH-1 THRU EH-4 FOR MORE INSTALLATION INFO

## STANDARD FEATURES

- DOCKLEVELER MODEL NUMBER: EH-68-20
- PIT WIDTH IS 74 INCHES
- PIT LENGTH IS 86 INCHES
- PIT DEPTH IS 24 INCHES AT FRONT, 23 3/4 INCHES AT BACK
- DOCK HEIGHT IS 48 INCHES (48 INCHES STANDARD)
- DOCKLEVELER CAPACITY (GROSS ROLLING LOAD) IS 20,000 LBS.
- VERTICAL SERVICE RANGE IS 12 INCHES ABOVE AND 12 INCHES BELOW DOCK
- INCLUDES (2) 1014-4.5 LAMINATED DOCK BUMPERS
- \*\*\*SINGLE AXLE CAPACITY NOT TO EXCEED 70% OF LOAD\*\*\*

### PLEASE CIRCLE SPECIFICATIONS:

<b>NEW</b>	(PIT) CONSTRUCTION
<b>EXISTING</b>	(PIT) CONSTRUCTION

- ALL STRUCTURAL STEEL CONSTRUCTION WELDING MEETS AWS. DESIGN, ENGINEERING, AND FABRICATION COMPLIES WITH OSHA & ANSI MH30.1
- REFER TO THE UNIT'S ELECTRICAL DIAGRAM FOR ELECTRICAL SERVICE REQUIREMENTS.
- INSTALL TO MEET ALL APPLICABLE STATE & LOCAL CODES FOR YOUR AREA!
- NOTE: ONE 18/2 STD AND 14/3 (FOR 1 PHASE) OR 14/4 (FOR 3 PHASE) STD CABLE (OR EQUIVALENT) MUST BE PROVIDED BY THE INSTALLER IN ORDER TO COMPLETE THE INSTALLATION.

FOR INTERNAL USE ONLY  
PROJECT SIGN OFF

SALES	
ENG.	
FAB.	
POWER	

### PLEASE CIRCLE SPECIFICATIONS:

POWER	<input checked="" type="checkbox"/> AC	<input type="checkbox"/> * DC	<input type="checkbox"/> * AIR/OIL
MOTOR VOLTAGE	<input type="checkbox"/> 115	<input type="checkbox"/> 208	<input checked="" type="checkbox"/> 230
	<input type="checkbox"/> 460		
DEDICATED CIRCUIT REQUIRED			
MOTOR PHASE	<input type="checkbox"/> SINGLE	<input checked="" type="checkbox"/> THREE	
CONTROL	<input checked="" type="checkbox"/> HAND	<input type="checkbox"/> * FOOT	
~ ALL BATTERY CHARGERS ARE 115V AC ~			
* BATTERY CHRG.	<input type="checkbox"/> REMOTE	<input type="checkbox"/> ON-BOARD	
* CHRG. INDICATOR	<input type="checkbox"/> YES	<input type="checkbox"/> NO	

\* AVAILABLE AT ADDITIONAL COST

## SPECIAL FEATURES

NONE

I, THE UNDERSIGNED, AGREE THAT THE PRODUCT AS REPRESENTED SATISFIES DESIGN AND DIMENSION REQUIREMENTS. I ALSO ACKNOWLEDGE MY DUTY TO CONFIRM PRODUCT AND INSTALLATION COMPLIANCE WITH ALL APPLICABLE FEDERAL, STATE AND LOCAL REGULATIONS AND STANDARDS.

**ANY MODIFIED UNITS ARE NON-RETURNABLE**

[ ] As drawn [ ] As marked

Signed: \_\_\_\_\_ Date: \_\_\_\_\_

Printed Name: \_\_\_\_\_

LEAD TIME WILL START UPON RECEIPT OF SIGNED APPROVAL DRAWING

APPROVAL

DISTRIBUTOR'S NAME:	HOF EQUIPMENT COMPANY	P.O.#	X
	PH: 888-990-1150	W.O.#	X
DRAWN BY:	TJM	DATE:	05/18/11
REFERENCE:	X	SCALE:	NTS
QUOTED LEAD TIME:	X	QUOTE #	X
		SALES:	X
		FILE NAME:	06-007-022