

DRUM STORAGE HARD TOP CONTAINER, DSHRT-2

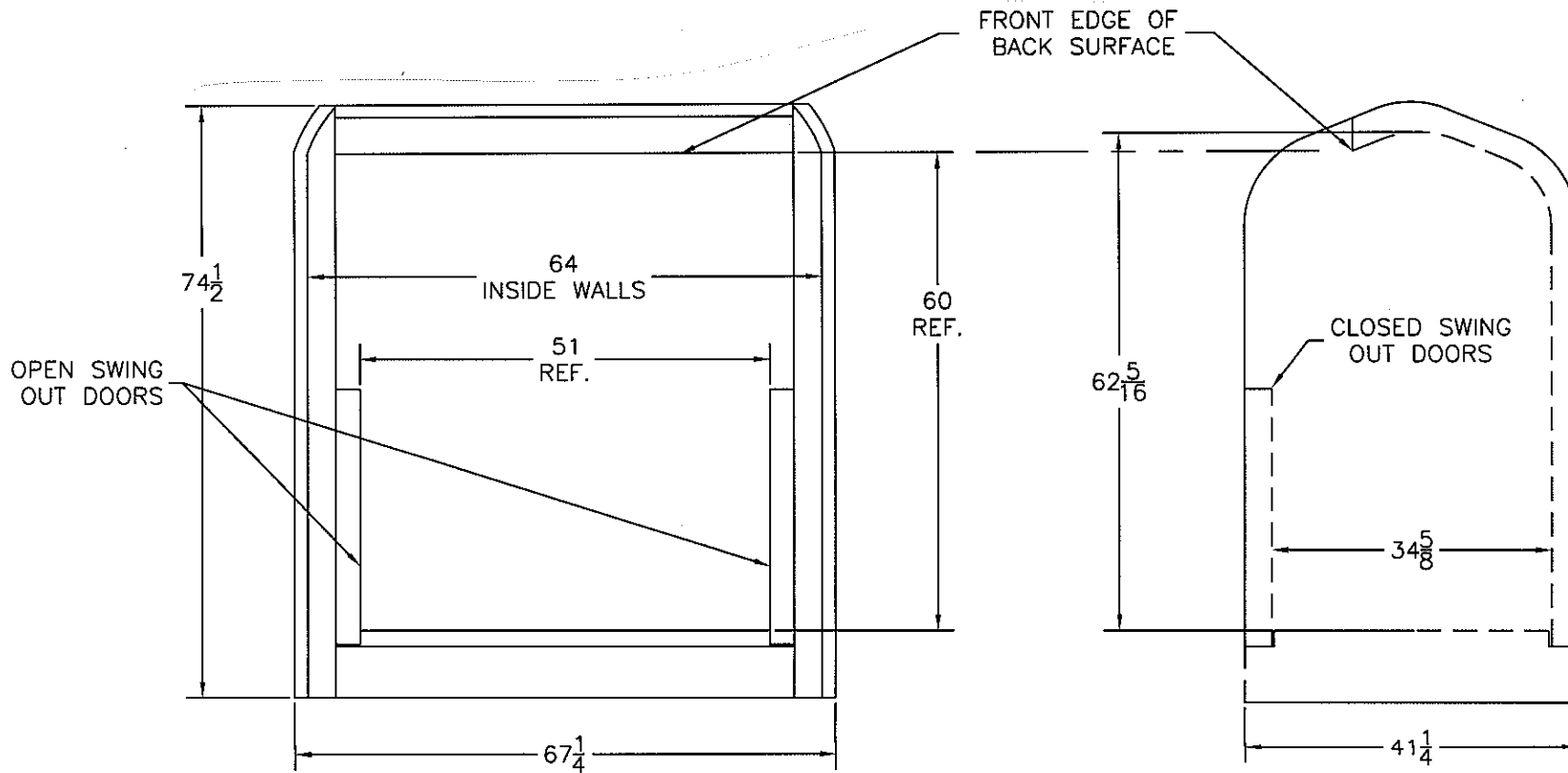

STANDARD FEATURES

MODEL NUMBER: DSHRT-2
 UNIFORM CAPACITY: 4,500#
 SUMP CAPACITY: 66 GALLONS
 DRUM CAPACITY: 2
 OVERALL WIDTH: $67\frac{1}{4}$ "
 OVERALL DEPTH: $41\frac{1}{4}$ "
 OVERALL HEIGHT: $74\frac{1}{2}$ "

SPECIAL FEATURES

NONE

All graphics provided are for reference only.
 If certain dimensions are critical please
 verify those dimensions with your salesperson

Any additions, deletions or
 omissions must be corrected
 on this drawing, as this drawing
 will be considered all inclusive.

A I, THE UNDERSIGNED, AGREE THAT THE PRODUCT AS REPRESENTED
 P SATISFIES DESIGN & DIMENSION REQUIREMENTS. I ALSO ACKNOWLEDGE
 P MY DUTY TO CONFIRM PRODUCT & INSTALLATION COMPLIANCE WITH ALL
 R APPLICABLE FEDERAL, STATE AND LOCAL REGULATIONS & STANDARDS.
 O **ALL SPECIAL UNITS ARE NON-RETURNABLE**
 V [] As drawn [] As marked
 A Signed: _____ Date: _____
 L LEAD TIME WILL START UPON RECEIPT OF SIGNED APPROVAL DRAWING

DISTRIBUTOR'S NAME:		P.O.#: -	
HOF EQUIPMENT COMPANY		W.O.#: -	
PH: 888-990-1150		SALES: -	
DRAWN BY: SR	DATE: 9-20-10	SCALE: NTS	
REFERENCE: -	QUOTE #:	DRWG./FILE NAME:	
QUOTED LEADTIME: -	QUOTE #:	DSHRT-2	