

CLASS II CARRIAGE MOUNTED RUG-RAM - CR-144-2

APPROX WEIGHT: 341.57 lbs.
 DOES NOT INCLUDE WEIGHT OF POWER OR PACKAGING!!!

*** ANY ADDITIONS, DELETIONS, OR OMISSIONS MUST BE CORRECTED ON THIS DRAWING AS THIS DRAWING WILL BE CONSIDERED ALL INCLUSIVE ***

ALL GRAPHICS PROVIDED ARE FOR REFERENCE ONLY. IF CERTAIN DIMENSIONS ARE CRITICAL PLEASE VERIFY THOSE DIMENSIONS WITH YOUR SALESPERSON

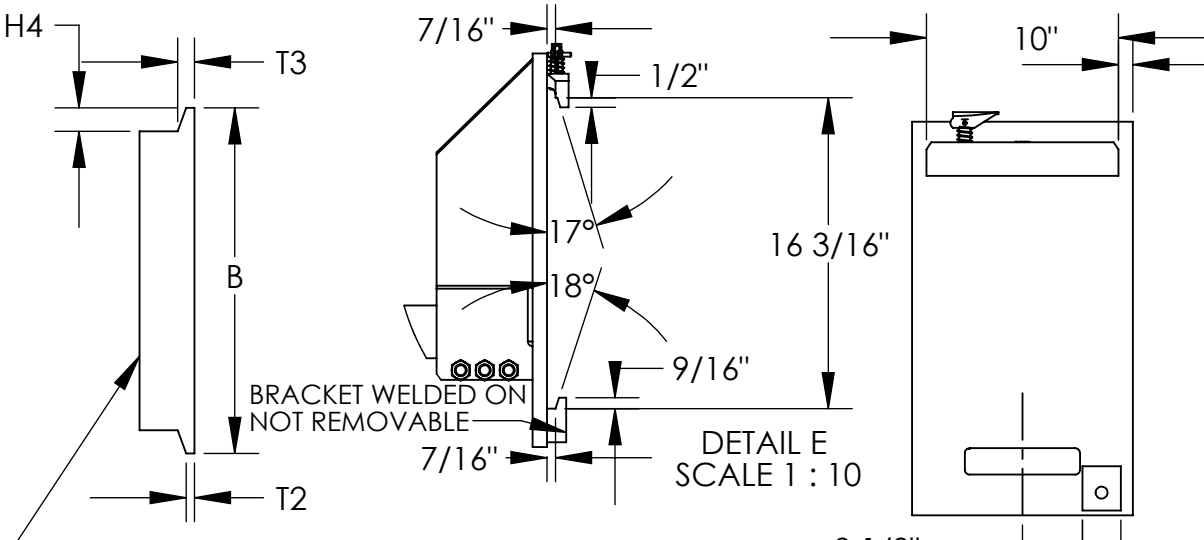
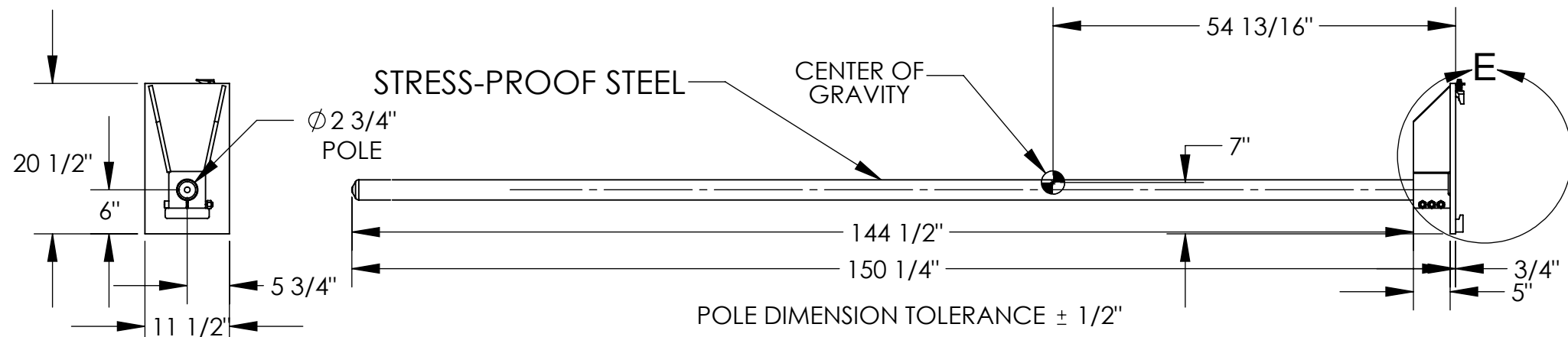

HORIZONTAL CENTER OF GRAVITY: 54 13/16"
 VERTICAL CENTER OF GRAVITY: 7"
 LOST LOAD: 338 LBS. (APPROX.)

NOTE: NEVER EXCEED LOAD CENTER RATING PER FORK TRUCK MANUFACTURER'S GUIDELINES. DO NOT USE THIS FORK TRUCK ATTACHMENT IF LOAD WILL EXCEED FORK TRUCK MANUFACTURER'S LOAD CENTER RATING.

DIMENSION TOLERANCE ± 1/4"

****NOTE****
 DUE TO VARIATIONS IN FORK TRUCK CARRIAGES, PLEASE HAVE THE CUSTOMER VERIFY THAT THEIR CARRIAGE WILL CONFORM TO THE DIMENSIONS SHOWN TO THE RIGHT. IF NOT, PLEASE HAVE THE CUSTOMER VERIFY DIMENSIONS B, T2, T3 & H4 TO BE ABLE TO QUOTE A SPECIAL BACKPLATE TO FIT.

SPECIAL FEATURES

NONE

APPROVAL

I, THE UNDERSIGNED, AGREE THAT THE PRODUCT AS REPRESENTED SATISFIES DESIGN AND DIMENSION REQUIREMENTS. I ALSO ACKNOWLEDGE MY DUTY TO CONFIRM PRODUCT AND INSTALLATION COMPLIANCE WITH ALL APPLICABLE FEDERAL, STATE AND LOCAL REGULATIONS AND STANDARDS.

UNITS REQUIRING APPROVAL DRAWINGS OR MODIFIED ARE NON-RETURNABLE

[] As drawn [] As marked

Signed: _____ Date: _____

Printed Name: _____

LEAD TIME WILL START UPON RECEIPT OF SIGNED APPROVAL DRAWING

STANDARD FEATURES

- MODEL NUMBER: CR-144-2
- CAPACITY: 1,800 LBS. UNIFORM CAPACITY
- POLE LENGTH: 144 1/2"
- POLE DIAMETER: 2 3/4"
- FITS CLASS II CARRIAGE
- DURABLE LIQUID PAINT BLUE FRAME

| FOR INTERNAL USE ONLY PROJECT SIGN OFF | |
|-------------------------------------------|--|
| SALES | |
| ENG. | |
| FAB. | |
| POWER | |

| | | | |
|-----------------------|-----------------|------------|--|
| DISTRIBUTOR'S NAME: | | P.O.# | |
| HOF EQUIPMENT COMPANY | | X | |
| PH: 888-990-1150 | | W.O.# | |
| | | X | |
| DRAWN BY: BCN | DATE: 5/18/2016 | SALES: X | |
| REFERENCE: X | SCALE: 1:20 | FILE NAME: | |
| QUOTED LEAD TIME: X | QUOTE # X | 08-007-102 | |