

ALL WHEEL STEER TRUCK - AWST-3672-PU

APPROX WEIGHT: 331.66 lbs.
 DOES NOT INCLUDE WEIGHT OF POWER OR PACKAGING!!!

*** ANY ADDITIONS, DELETIONS, OR OMISSIONS MUST BE CORRECTED ON THIS DRAWING AS THIS DRAWING WILL BE CONSIDERED ALL INCLUSIVE ***
 ALL GRAPHICS PROVIDED ARE FOR REFERENCE ONLY. IF CERTAIN DIMENSIONS ARE CRITICAL PLEASE VERIFY THOSE DIMENSIONS WITH YOUR SALESPERSON

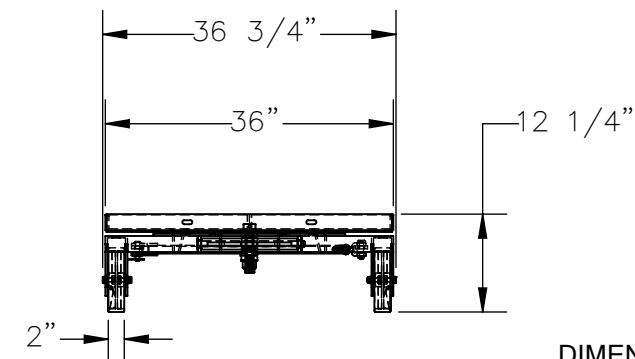
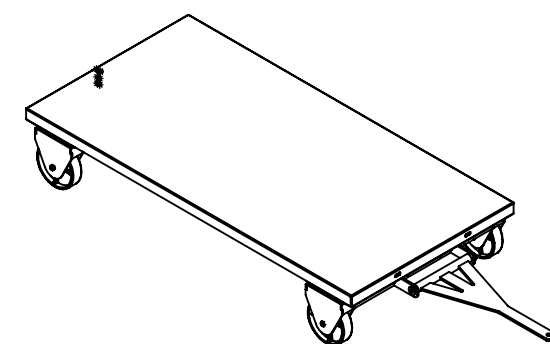
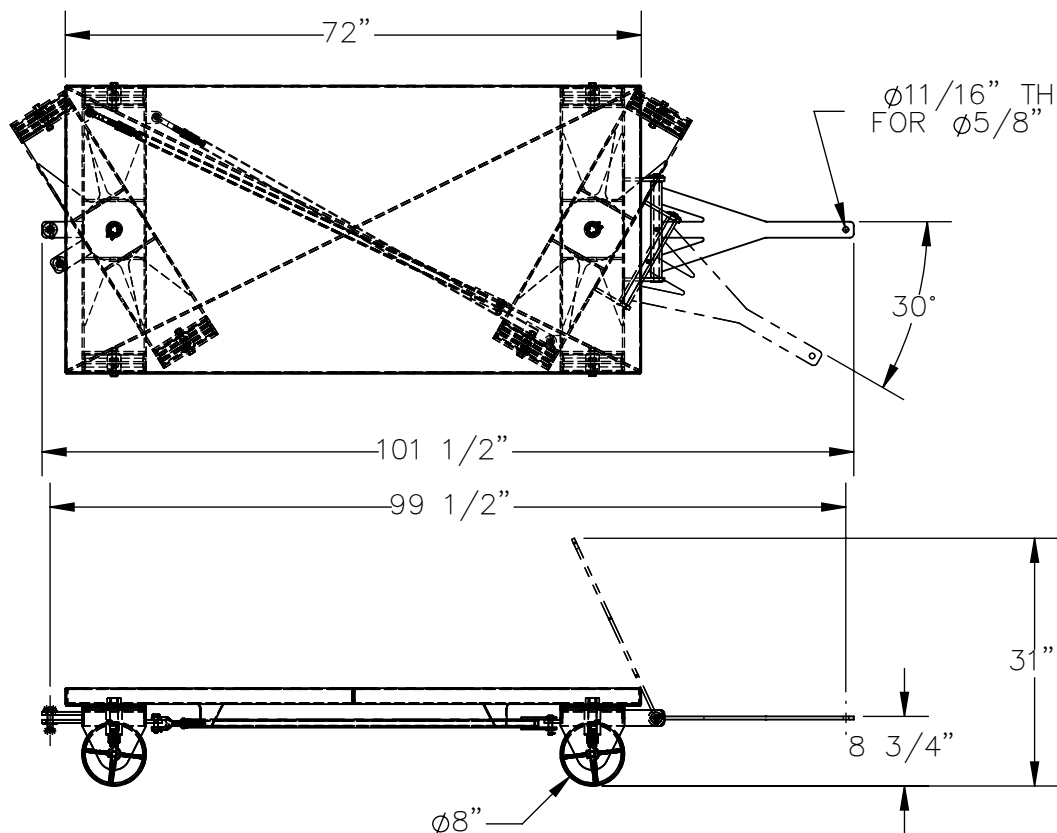

DIMENSION TOLERANCE $\pm 1/4$ "

STANDARD FEATURES

- MODEL NUMBER IS AWST-3672-PU
- DURABLE STEEL CONSTRUCTION
- UNIFORM CAPACITY IS: 3,600 LBS.
- OVERALL WIDTH IS: 36 3/4"
- DECK WIDTH IS: 36"
- OVERALL LENGTH IS: 101 1/2"
- DECK LENGTH IS: 72"
- OVERALL HEIGHT IS: 31"
- DECK HEIGHT IS: 12 1/4"
- TONGUE NEUTRAL HEIGHT IS: 8 3/4"
- POLY ON STEEL CASTERS: 8"x2"
- TOUGH BAKED IN POWDER COAT YELLOW FINISH

SPECIAL FEATURES

-NONE

APPROVAL

I, THE UNDERSIGNED, AGREE THAT THE PRODUCT AS REPRESENTED SATISFIES DESIGN AND DIMENSION REQUIREMENTS. I ALSO ACKNOWLEDGE MY DUTY TO CONFIRM PRODUCT AND INSTALLATION COMPLIANCE WITH ALL APPLICABLE FEDERAL, STATE AND LOCAL REGULATIONS AND STANDARDS.
UNITS REQUIRING APPROVAL DRAWINGS OR MODIFIED ARE NON-RETURNABLE
 As drawn As marked

Signed: _____ Date: _____
 Printed Name: _____

LEAD TIME WILL START UPON RECEIPT OF SIGNED APPROVAL DRAWING

FOR INTERNAL USE ONLY PROJECT SIGN OFF	
SALES	
ENG.	
FAB.	
POWER	

DISTRIBUTOR'S NAME:		P.O.#
HOF EQUIPMENT COMPANY		X
PH: 888-990-1150		W.O.#
DRAWN BY: JGP		X
DATE: 8/26/2020		SALES: X
REFERENCE: X	SCALE: 1:24	FILE NAME:
QUOTED LEAD TIME: X	QUOTE # X	16-007-506