

# GAS POWERED ALL TERRAIN PALLET TRUCK - ALL-T-2-GPT-L-PT-HD

\*\*\*ANY ADDITIONS, DELETIONS, OR OMISSIONS MUST BE CORRECTED ON THIS DRAWING AS THIS DRAWING WILL BE CONSIDERED ALL INCLUSIVE\*\*\*  
 APPROX WEIGHT: 1361 lbs.  
 DOES NOT INCLUDE WEIGHT OF POWER OR PACKAGING!!!

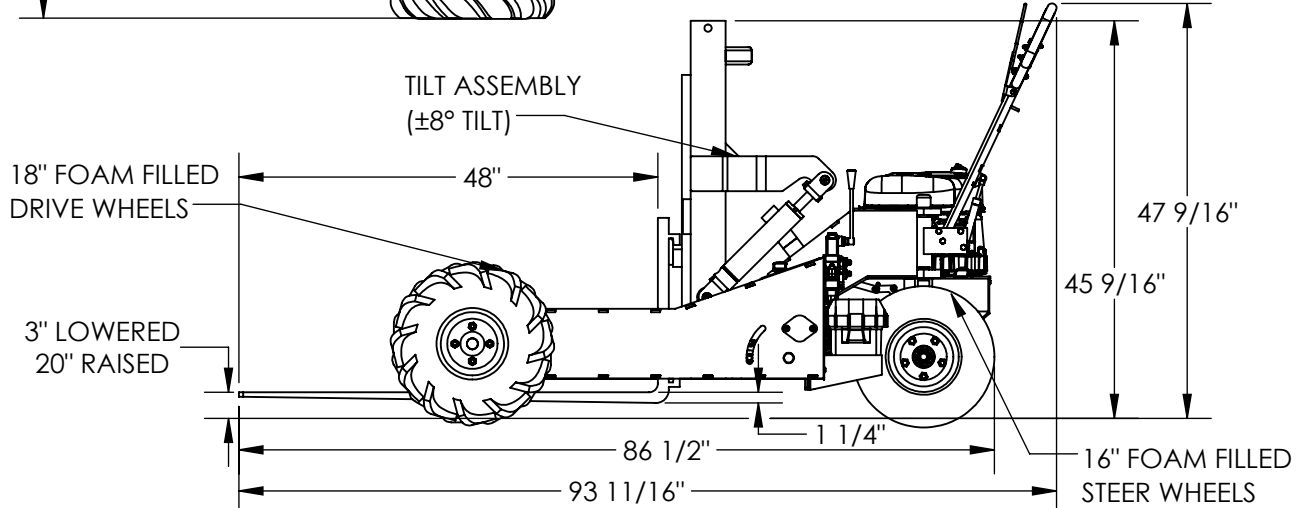
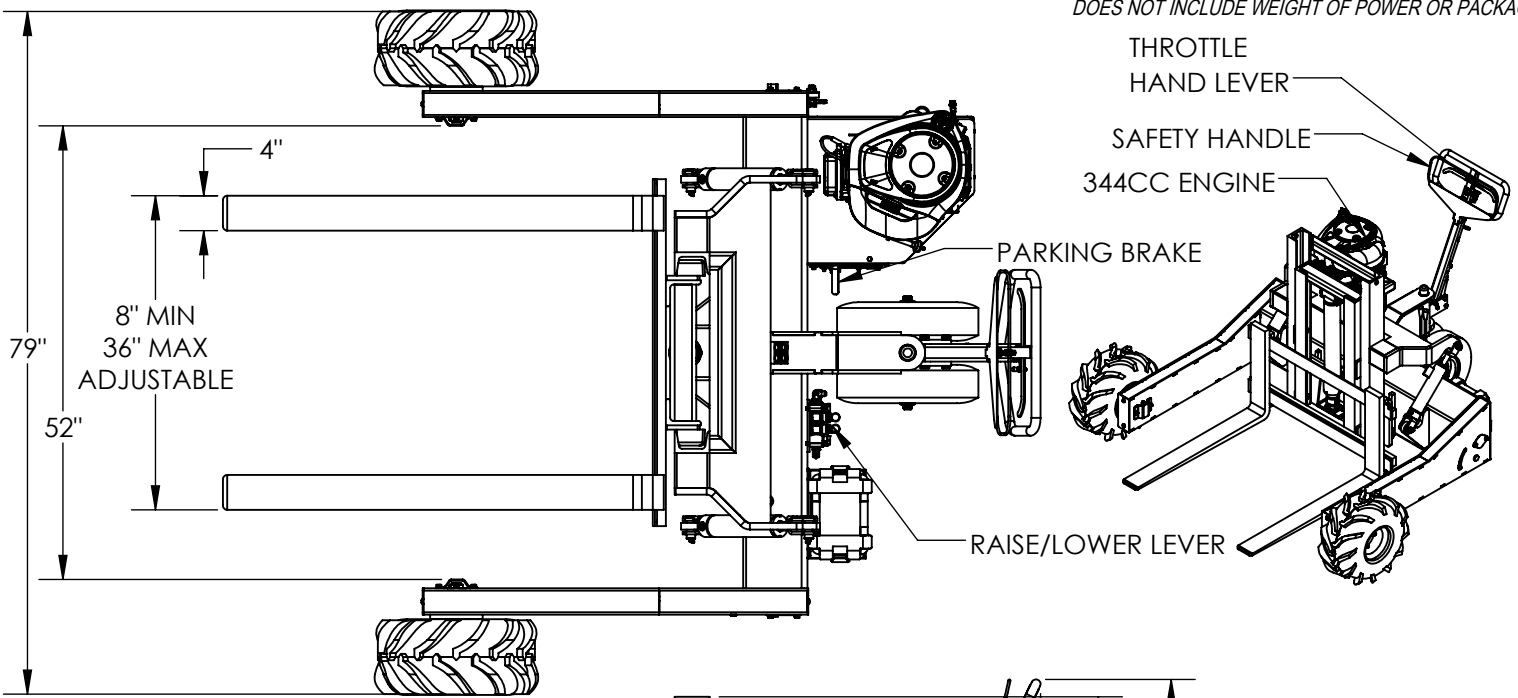

FOR INTERNAL USE ONLY  
 PROJECT SIGN OFF

SALES	
ENG.	
FAB.	
POWER	

ALL GRAPHICS PROVIDED ARE FOR REFERENCE ONLY. IF CERTAIN DIMENSIONS ARE CRITICAL PLEASE VERIFY THOSE DIMENSIONS WITH YOUR SALESPERSON  
 DIMENSION TOLERANCE ± 1"

## STANDARD FEATURES

- MODEL NUMBER IS ALL-T-2-GPT-L-PT-HD
- CAPACITY IS 2,000 LBS
- OVERALL WIDTH IS 79"
- STRADDLE WIDTH IS 52"
- SERVICE HEIGHT IS 3" TO 20"
- FORKS ARE ADJUSTABLE FROM 8" TO 36"
- FORKS ARE 1 1/4" THICK X 4" WIDE X 48" LONG
- OVERALL LENGTH IS 93 11/16"
- OVERALL HEIGHT IS 47 9/16"
- 18" FOAM FILLED FRONT WHEELS
- SAFETY HANDLE WITH FORWARD/NEUTRAL/REVERSE
- ±8° POWER TILT FOR FORKS
- 344CC BRIGGS AND STRATTON ENGINE WITH ELECTRIC START
- HAND LEVER TO CONTROL LIFT/LOWER
- DURABLE LIQUID PAINT BLUE FINISH

**A P P R O V A L**

I, THE UNDERSIGNED, AGREE THAT THE PRODUCT AS REPRESENTED SATISFIES DESIGN AND DIMENSION REQUIREMENTS. I ALSO ACKNOWLEDGE MY DUTY TO CONFIRM PRODUCT AND INSTALLATION COMPLIANCE WITH ALL APPLICABLE FEDERAL, STATE AND LOCAL REGULATIONS AND STANDARDS.

**UNITS REQUIRING APPROVAL DRAWINGS OR MODIFIED ARE NON-RETURNABLE**

[ ] As drawn [ ] As marked

Signed: \_\_\_\_\_ Date: \_\_\_\_\_

Printed Name: \_\_\_\_\_

LEAD TIME WILL START UPON RECEIPT OF SIGNED APPROVAL DRAWING

DISTRIBUTOR'S NAME:		P.O.#	
HOF EQUIPMENT COMPANY		X	
PH: 888-990-1150		W.O.#	
DRAWN BY: KGH		X	
DATE: 6/27/2018		SALES: X	
REFERENCE: X		SCALE: 1:22	
QUOTED LEAD TIME: X		QUOTE #	
X		50-007-028	