

**PROPRIETARY INFORMATION**

THIS DRAWING IS THE CONFIDENTIAL PROPERTY OF ENDURA-VEYOR, INC. AND TRANSMITTED IN CONFIDENCE. THE REPRODUCTION, USE OR DISCLOSURE, IN WHOLE OR IN PART, OF THE DESIGN OR DETAILS CONTAINED HEREIN IS PROHIBITED WITHOUT THE EXPRESS WRITTEN PERMISSION OF ENDURA-VEYOR, INC.

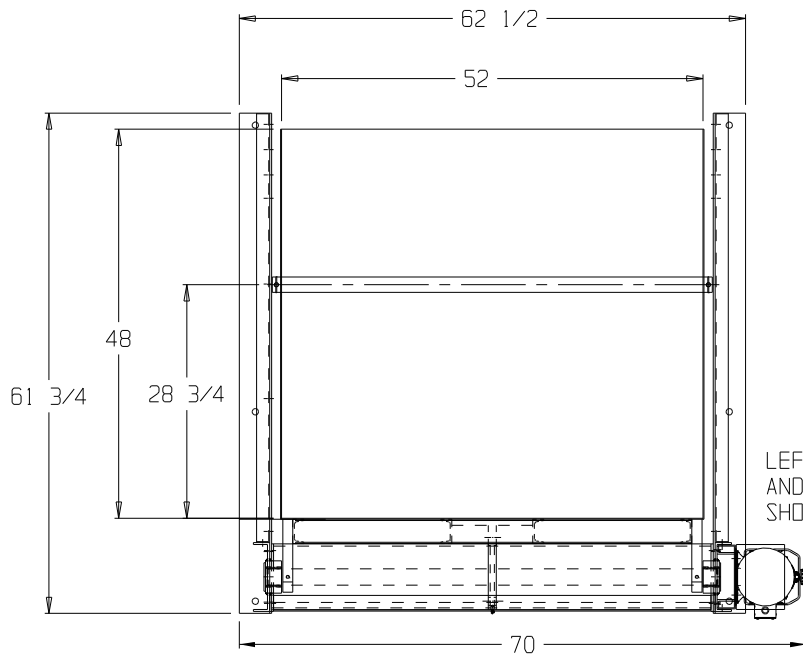

SHIPPING DIMENSIONS:  
74 "L x 87 "W x 66 "H

SHIPPING WEIGHT:  
1700 LBS

LEFT HAND PUMP AND CONTROL SHOWN

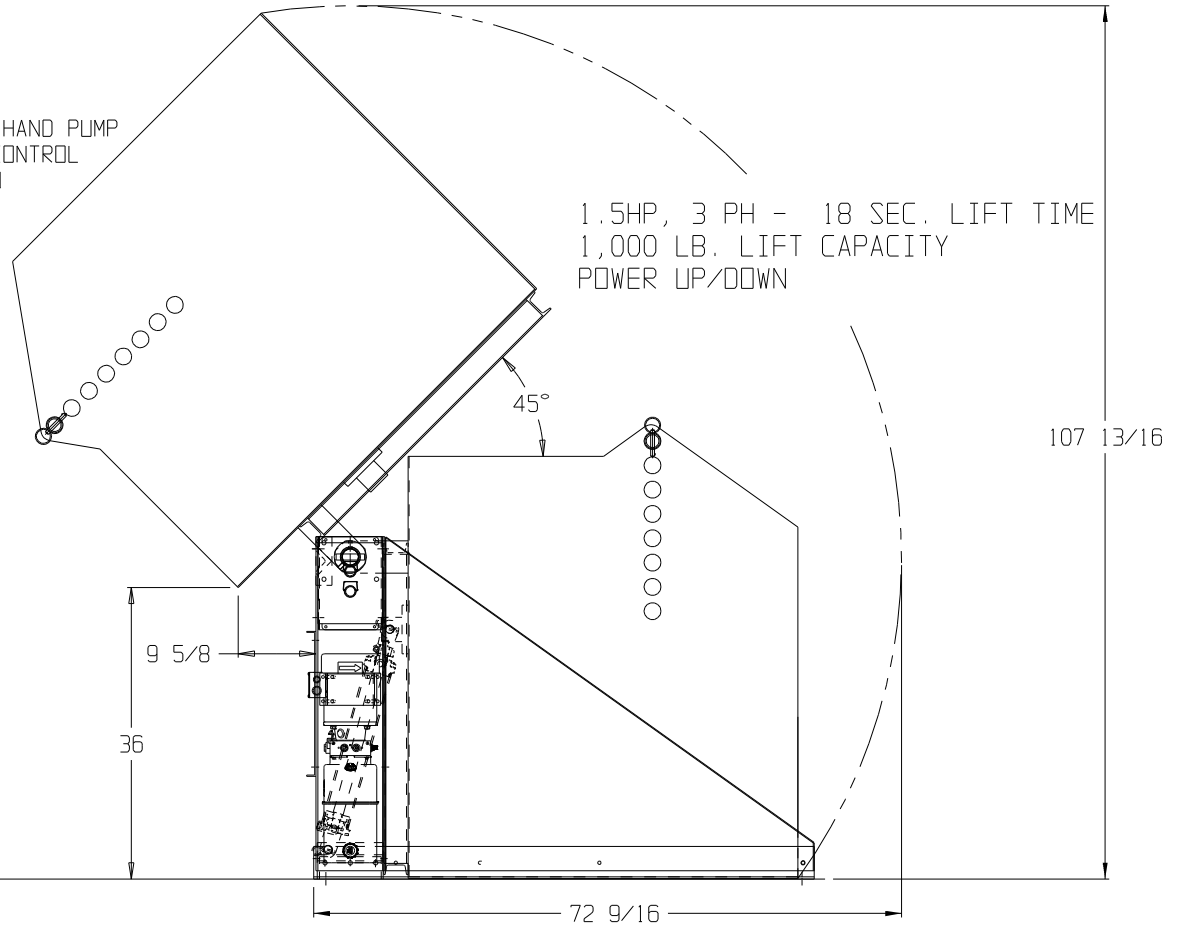
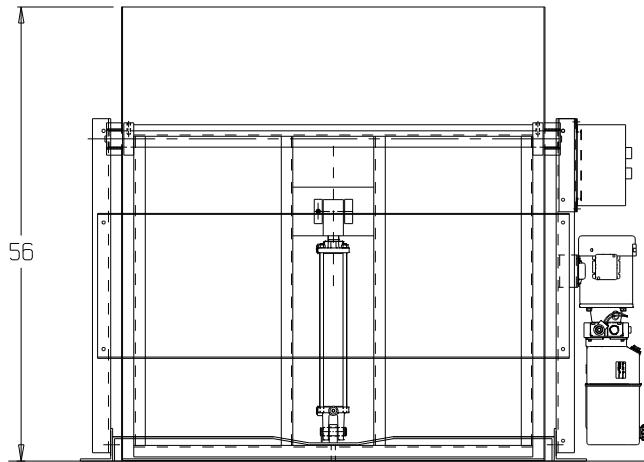

**SAFETY REVIEW**

**APPLICATION REVIEW**

**PROPOSAL DRAWING**

THE NEED FOR SAFETY DEVICES VARIES WITH EACH APPLICATION OF THIS PRODUCT. THIS DRAWING MAY NOT INCLUDE ALL APPROPRIATE SAFETY DEVICES FOR YOUR APPLICATION. AS SYSTEMS INTEGRATOR, PLEASE ADVISE YOUR CUSTOMER OF DEVICES THAT ARE APPROPRIATE FOR HIS/HER APPLICATION, BASED ON YOUR SAFETY ASSESSMENT. DEVICES MAY INCLUDE, BUT ARE NOT LIMITED TO THOSE SUCH AS, ADDITIONAL GUARDING, SAFETY CONTROLS, BARRICADES, END STOPS, ETC. COMPLIANCE WITH FEDERAL, STATE, OSHA AND LOCAL LAWS OR CODES ARE THE RESPONSIBILITY OF BOTH YOU, AS THE SYSTEMS INTEGRATOR/DISTRIBUTOR, AND THE END USER.

PLEASE REVIEW THE CONVEYOR DESIGN FOR ITS ABILITY TO FUNCTION PROPERLY IN YOUR INTENDED APPLICATION. SYSTEM INTEGRATION AND APPLICATION REVIEW ARE NOT THE RESPONSIBILITY OF ENDURA-VEYOR INC. THEREFORE, ENDURA-VEYOR INC. MAKES NO CLAIM AS TO THE PERFORMANCE OF THIS DESIGN FOR ANY PARTICULAR PURPOSE OR APPLICATION.

INFORMATION MAY CHANGE AT TIME OF FINAL APPROVAL DRAWING

PAINT COLOR:  
RAL-5019 CAPRI BLUE

**HOF EQUIPMENT COMPANY**  
PH: 888-990-1150

TITLE:  
CONTAINER DUMPER #180-36-5248

JOB NO: Q68354  
DRAWN BY: PFG  
SCALE: N/A  
DATE: 10/25/21  
REVISION: -

ORG. NO.:  
**PROPOSAL**